

STEINER
THUESEN
PLLC

IRRIGATION DESIGN
LANDSCAPE ARCHITECTURE
GOLF COURSE ARCHITECTURE

EXPERIENCE *and*
INNOVATION

IRRIGATION DESIGN



FIRM PROFILE

Steiner Thuesen PLLC is a Landscape and Golf Course Architectural Firm located in Billings, Montana. The principal is a Registered Landscape Architect who has practiced in Montana and the northern Rocky Mountain region since 1973, providing the firm with a thorough understanding of the region's unique climate, plant materials and construction challenges. This experience is applied to each of our projects.

Founded in 1984, the practice has focused on providing creative yet practical solutions to site design and golf course architectural challenges with special attention given to client responsiveness and quality of the constructed product.

The firm provides a full range of services including master planning, site design, construction document preparation, estimating, and periodic construction observation. Recent contracts have enlisted the firm's services for community and regional parks, sports facilities, new construction and remodeling of golf courses, site improvements for retail centers and state universities, and major irrigation projects. Our experience with construction of projects is invaluable in developing realistic budgets, buildable plans and accurate cost estimates for planning and design projects.



IRRIGATION DESIGN

RIVERSIDE CEMETERY

Cody, Wyoming

Riverside Cemetery is an old and very historic cemetery, including graves of many Wyoming pioneers. Steiner Thuesen PLLC has been involved in ongoing phased improvements to this historic resource for the Riverside Cemetery District.

Initially an analysis of the design criteria and the existing water supply system was conducted to determine if and how these existing systems could be reused and what the precipitation design criteria and irrigation scheduling parameters should be. With that information in hand plans were drawn to replace the old manual quick coupling irrigation system with a new fully automatic underground irrigation system for the entire 31 acre property. From this design bid documents were created to permit construction of the improvements in phases, the cost of which corresponded to the annual budget for site improvements.

To date the irrigation system replacement has been completed through two contracts totaling \$276,000.00. Phase one construction included new self flushing ditch diversion works and modifications to the supply pipeline. A new digitally controlled booster pump with self cleaning filtration system was also included in phase one. The phase two project served the oldest part of the cemetery with new irrigation. This portion of the job was designed to work with the many mature trees and large monuments located in this area of the cemetery. The system is controlled by a simplified master satellite control system. This easy to operate system offers digital timing accuracy at the satellite controllers and basic global operations from the electro-mechanical central controller.

A master plan for landscape enhancements and site furnishings for Riverside Cemetery has been developed. This includes designation of planting areas in undeveloped parts of the property, an overall conceptual planting plan with selection of desirable plant species, entry area improvements, a visitor accessible directory kiosk, a shelter and provisions for ceremonies, potable water and raw water hydrants, and location of benches, signage and planters throughout the property. Completion of these improvements will provide a better sense of place and more recognizable image for the cemetery.

We also prepared construction plans to provide site development improvements for the cemetery office and shop area. This project includes improvements to the drainage and parking, the nursery, earth and materials stockpile areas, an organic waste composting area, and other improvements to promote ease of maintenance operations.

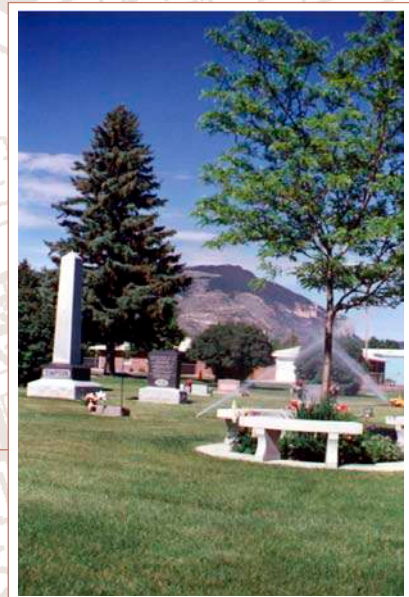

IRRIGATION DESIGN

BYRON & PENROSE CEMETERIES

Byron, Wyoming

Byron Cemetery

Bid documents were prepared to replace the manual quick coupling irrigation system with a modern fully automatic irrigation system for this 5 acre cemetery. Work was performed for the Byron Cemetery District.

The work included creation of accurate mapping of the overall property, existing plant locations, and individual blocks and graves. The system was designed to use the existing centrifugal pump, with improvements for automatic pump control. Since the water source was an irrigation ditch, an automatic self cleaning filtration system was added to the water supply. The system used a single stand-alone controller and rotor type sprinkler heads.

Following completion of the construction work in early summer 1997, record drawings of the project were prepared and delivered to the Owner in archival hard copy and digital form. Since these drawings show all burial plots they will be used to maintain a graphic of individual burial locations by the District.

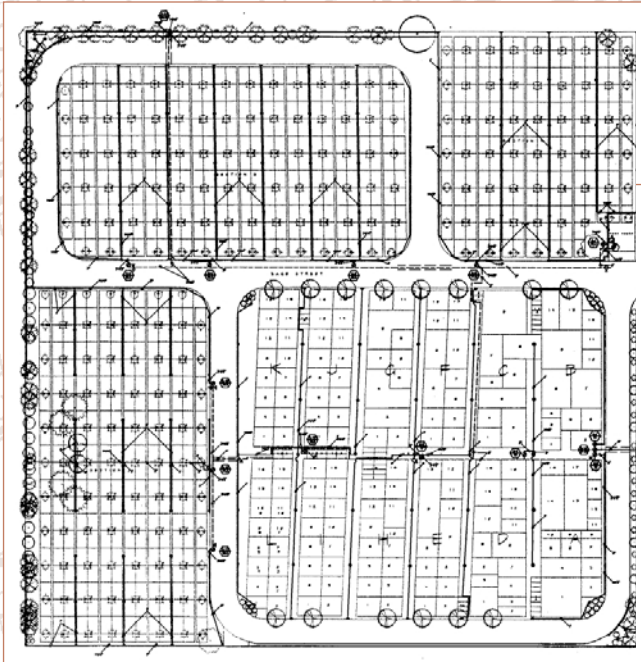

Penrose Cemetery

Bid documents were prepared to replace the manual quick coupling irrigation system with a modern fully automatic irrigation system for this 3 acre cemetery for the Byron Cemetery District.

The work included creation of accurate mapping of the overall property, existing plant locations, and individual blocks and graves. The system included and new submersible pump and electrical improvements for automatic pump control and motor protection. Since the water source was an irrigation ditch, an automatic self cleaning filtration system was added to the water supply. The system used a single stand-alone controller and rotor type sprinkler heads.

Following completion of the construction work in early summer 1997, record drawings of the project were prepared and delivered to the Owner in archival hard copy and digital form. Since these drawings show all burial plots they will be used to maintain a graphic of individual burial locations by the District.



KEMMERER & DIAMONDVILLE CEMETERIES

Kemmerer, Wyoming

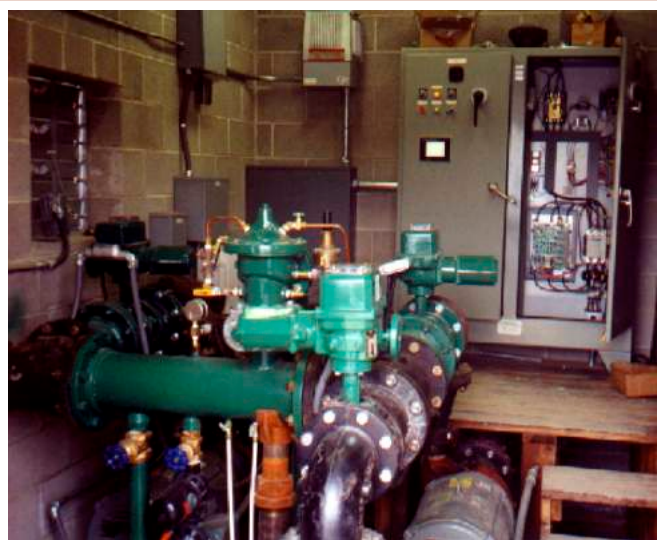

When Kathy Slovernick, manager of the South Lincoln Cemetery District, first called our office in 1998 she described her situation as “living with the pump from hell”. The District had recently commissioned a local engineering firm to convert their temporary diesel powered irrigation pump serving Kemmerer Cemetery to a permanent electric installation. The pump drew water from the heavily silt laden Ham’s Fork River, and no filtration had been provided, resulting in many maintenance difficulties.

Steiner Thuesen PLLC completely renovated the pump, providing a new computerized control interface, new custom-designed automatic self-flushing river intake, and automatic self-flushing discharge filter. Having recently made a major investment in the new pumps and motors, the Cemetery District Board did not want to replace the centrifugal units, which were losing prime and developed insufficient head. Plans were then implemented to provide a small pressure maintenance pump and to achieve positive prime for the twin main pumps. A new self-governing computer controlled booster pump was installed in the cemetery, which is located uphill some distance from the water source, to develop sufficient pressure to operate underground sprinkler equipment. The existing irrigation system within the cemetery was then completely replaced and automated.

At the nearby hillside Diamondville Cemetery potable water was used for irrigation. The City water tank was located at the top of the cemetery. Therefore water pressure was very low near the tank and increased as the hill descended to the lower side of the cemetery. A fully automatic variable frequency drive booster pump was designed to provide working pressure for the newly installed modern underground sprinkler equipment. Pressure regulating valves were used in conjunction with the booster pump, and lateral piping was laid cross slope, to provide uniform pressure at each sprinkler head on the property.

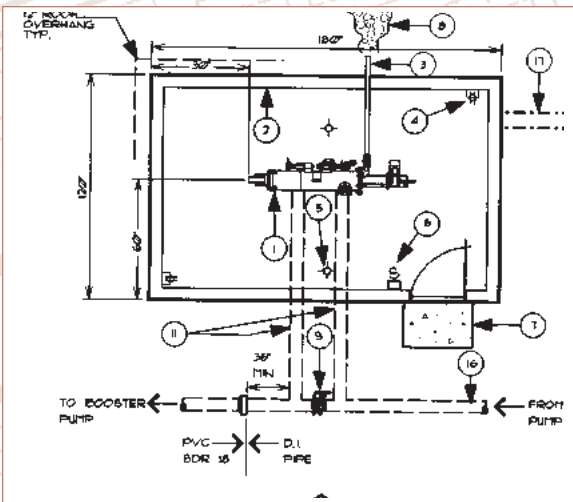

Both cemetery irrigation systems were controlled by a simple centralized controller which communicated with field satellite controllers by radio. The control system can also be operated with hand-held radios which double as pagers for the maintenance staff, saving a great deal of labor.

A total of 52 acres of cemetery were irrigated at a cost of \$485,000 including all pump work, underground sprinkler systems and controls. Construction was completed in 1999. The “pump from hell” was tamed.

IRRIGATION DESIGN

PINEDALE CEMETERY

Pinedale, Wyoming

Plans for automatic irrigation of the Pinedale, Boulder, and Mt. Olivet Cemeteries were developed for the Upper Green River Cemetery District in 2005. The automated systems eliminated the need to travel to Boulder and Mt. Olivet Cemeteries on a daily basis to set manual heads. The new system at Mt. Olivet eliminated the use of a diesel-powered generator also reducing maintenance costs.

A new potable water line was installed at the Pinedale Cemetery eliminating the reliance on the unpredictable raw water supply formerly used. A variable frequency drive booster pump was installed to provide pressure necessary for the proper operation of the new sprinkler heads.

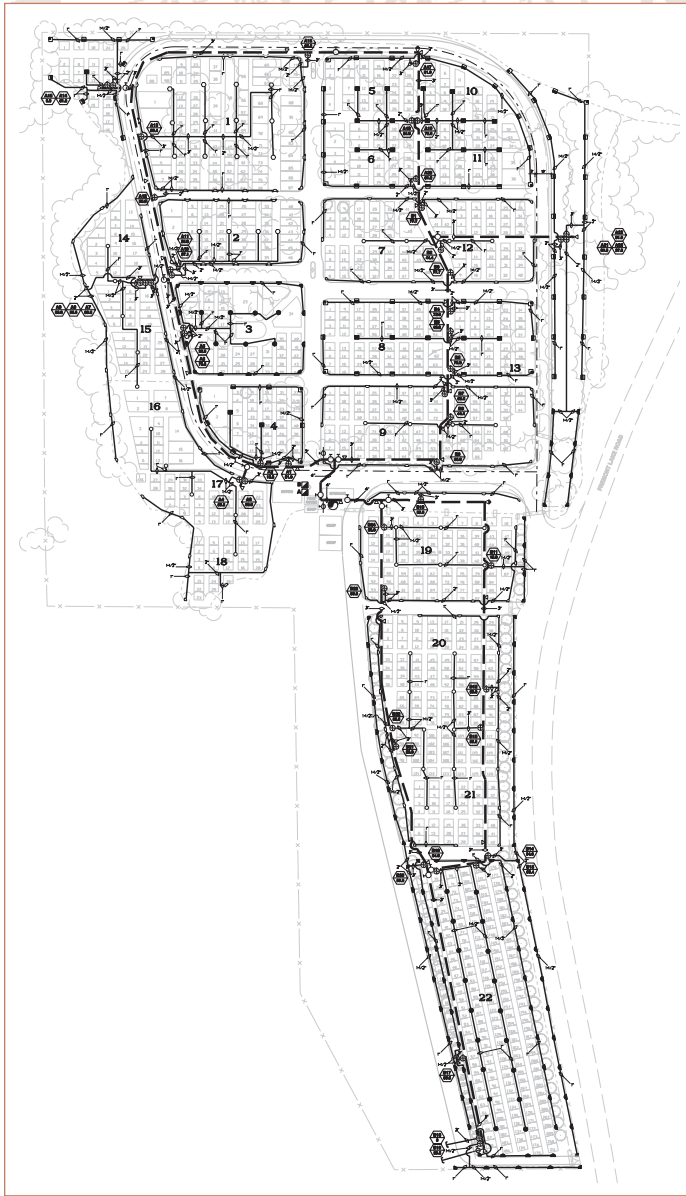

PLAINVIEW CEMETERY

Big Piney, Wyoming

At the completion of an existing irrigation system evaluation, the Big Piney Cemetery District retained the design services of Steiner Thuesen PLLC to design a new pump station. The pump station would be designed to service the existing cemetery as well as any future expansion.

Installation of the new pump station and supply line began in the fall of 2005 and was completed in early spring of 2006. The new pump station supplies water to the existing 14 acres of turf and landscaping 135 feet above the raw water source. The irrigation mainline was converted to a pressurized system. The mainline pressure is automatically controlled by the pump station that operates on a variable frequency drive (VFD) adjusting pump speeds on the fly based on downstream demand.

Because of the remote location of the pump station, an electronic butterfly valve backup was incorporated into the station. In the event of a VFD failure, the electronic butterfly valve backup will come on-line immediately allowing irrigation to continue without any downtime.



EVANSTON CEMETERY

Evanston, Wyoming

In 1999, the City of Evanston commissioned a local engineering firm to design a new water supply, pumps and filtration system for the city cemetery.

In February of 2000, Steiner Thuesen PLLC was hired to design a replacement irrigation system for 17 acres of the cemetery and to make any necessary modifications to the recently constructed pump system for automation of the pumps and to provide a workable operator interface.

A new computerized control interface using a touch screen was provided for the pumps. The newly designed irrigation system extended the City's existing Central Irrigation Control System and provides for easy future expansion of the irrigation system as the cemetery continues to develop.

The irrigation system replacement and pump station modifications were installed in 2001.

"I appreciate the length that you went to ensuring that every detail of the job was as it was supposed to be."

Bob Morgan,
Parks Supervisor



CROWN HILL CEMETERY

Powell, Wyoming

Steiner Thuesen PLLC was hired by the Crown Hill Cemetery District to provide master planning, construction phasing, and cost estimating for the replacement of the Cemetery irrigation system. The existing manual system was operated during the day with heads being set manually by Cemetery personnel.



Initially a feasibility study was conducted and preliminary costs were developed for the replacement project. Based on the projected costs, the project was broken into four phases. The initial phase included the replacement of the existing pump and supply line. A new, fully automated pump station supplying 900 GPM was designed and installed along with a new supply line to the cemetery.



The remaining three phases were completed over an eight month period. Five stand-alone controllers are used to operate the new irrigation system. In all, 42 acres of automated irrigation were installed. The new system is operated during the evening reducing the amount of water that is applied while allowing Cemetery maintenance to take place during regular business hours.

IRRIGATION DESIGN

AMEND PARK IRRIGATION

Billings, Montana



A multi-use park master plan was prepared for this 60 acre community park in association with Fischer Associates in 1984. This far sighted plan envisioned four groups of multiple use sports fields, traditional park uses such as picnics and trails, tennis courts, volleyball, basketball, an amphitheater and expandable parking. Storm water detention facilities were integrated with the design.

More recently the park master plan has been revised to develop the park as a dedicated soccer facility under a partnership agreement with the Magic City Soccer League and the Amend Park Development Council. The new plan provides 5 soccer field complexes of two fields each, with a centralized concession and parking field.

Steiner Thuesen PLLC designed the irrigation system for the entire park under the new master plan. Construction of the first complex and associated parking field is complete, as is the rough grading for the remainder of the park. The remaining four field complexes were completed in spring 1999. Since its completion, Amend Park has hosted many high school tournaments, including the 2001 AA championships and western regional tournament.

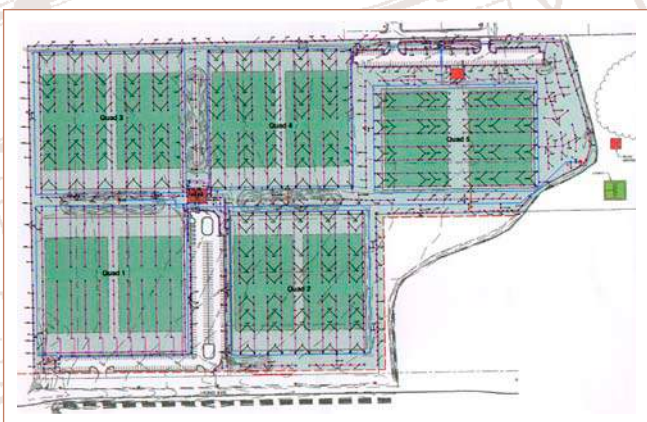

KALISPELL YOUTH ATHLETIC COMPLEX

Kalispell, Montana



This project includes master planning, cost budgeting and phasing, and preparation of detailed construction documents for a large scale athletic park located adjacent to Flathead Community College between Kalispell and Whitefish, Montana. The project scope included development of the 145 acre site with eight soccer fields, eight softball fields built to ASA specifications, eight Pee Wee Baseball fields, three Babe Ruth Baseball fields, and ancillary facilities including concessions, restrooms, utilities, roads and parking, landscaping and automatic irrigation. The development will also include traditional park and green belt spaces, two playgrounds, walking paths and trails, and an interpretive area. Ultimately, the project will serve as a regional athletic complex representing an investment in excess of \$5 million.

This large project is being addressed by a team of three consulting firms including Steiner Thuesen PLLC, Sitescape Associates, and Carver Engineering. Our role on the team is to assist the local firms with park and athletic facility planning and design expertise for development of the master layout plan, cost projections and phasing. Steiner Thuesen PLLC was also solely responsible for planning and design of the parks irrigation system, drainage systems, and special playfield design elements. The first phase of construction was completed in 1998.

IRRIGATION DESIGN

GREAT FALLS YOUTH SOCCER PARK

Great Falls, Montana

The design team of Steiner Thuesen PLLC, PRZ International, and TD&H Engineering Consultants was retained to develop a master plan, prepare construction documents and oversee construction of a new 70-acre soccer complex for the City of Great Falls.

Steiner Thuesen PLLC was lead in overseeing all master planning efforts. In addition to meetings with the soccer committee, several public meetings were held. Through the process, a master plan was developed that achieved the goals set forth by the soccer committee and the community. The goals included the construction of 15 fields, adequate parking, a pavilion with a concession area, restrooms, meeting and changing rooms, covered patio area, and landscaping. Through the implementation of this project, a beneficial public-private partnership representing the AYSO, Electric City Youth Soccer, High School and Adult Soccer groups, the City of Great Falls, and the Great Falls School District has been created.

Fields can be rotated 90 degrees allowing play at concentrated wear areas to be reduced. Each field will accept multiple layouts of smaller fields allowing play for all age groups.

A system of pathways runs throughout the site providing access to all of the fields. This network of paths also serves as jogging and walking paths, cross-country ski trails, etc. A maintenance yard and shop are located at the southwest corner of the site.

The underlying goal of the soccer fields is to develop a turf that will grow as fast or faster than it is being worn off through play.



This was accomplished by strict construction standards and by the incorporation of amendments to produce a growing medium capable of sustaining healthy turf. An incubated seeding process was used resulting in germination within 4-6 days.

Following approval of the master plan, Steiner Thuesen PLLC focused on the design of a state of the art irrigation system that is supplied by city water. The control system will monitor the weather and adjust run times based on the daily weather. This will aid tremendously in keeping maintenance expenditures as low as possible by eliminating over-watering and detecting any problems that develop in the system during operation.



HOMESTEADER PARK

Powell, Wyoming

The City of Powell Parks & Recreation Department retained Steiner Thuesen PLLC to plan and design a new irrigation system for Homesteader Park. The project scope included design of an irrigation central control system and construction management during the installation process.

The design of the systems and construction management included GPS mapping of the site. The data was imported into our CAD environment to be used as base maps for the irrigation system design. The completed design will be exported back into the GPS environment and used to provide layout and staking of the new irrigation system. During installation of the systems, the as-built information will be collected with a GPS system and used to create record drawings for use by the Owner.

One of the requirements of the design mandated that the irrigation system operate within an 8 hr/day watering window to allow sufficient time for maintenance activities and minimize user conflicts. This was accomplished through design of a highly efficient system with a scheduling coefficient of 1.2 or

better and fully automated pump stations capable of delivering the high flows necessary to meet the 8-hour water window requirement. One new well will be developed and two fully automated pump stations will be installed.

Following completion of the irrigation system Master Plan, Phase 1 Construction Documents were prepared. Construction of the new irrigation system will be completed in 4 phases. The estimated value of construction for this project is \$800,000.

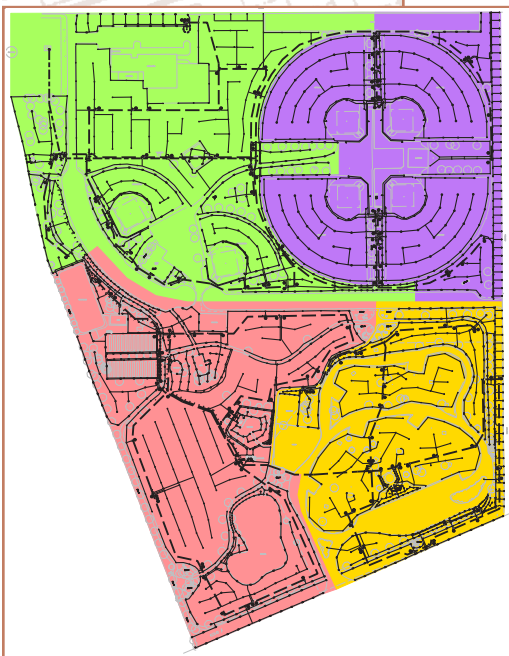
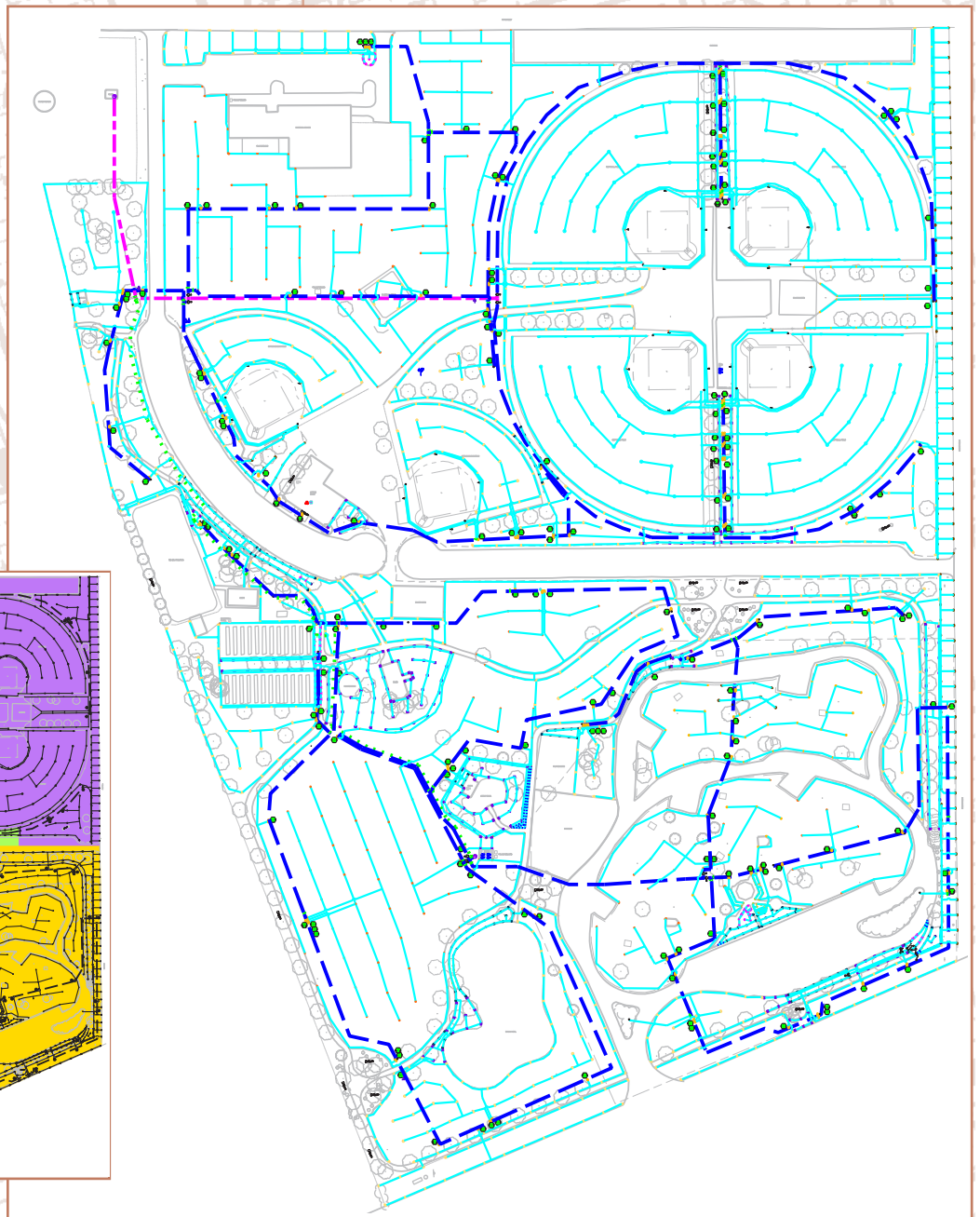

IRRIGATION DESIGN

CITY OF BILLINGS- PARKS, RECREATION & PUBLIC LANDS

Billings, Montana

The City of Billings, Parks, Recreation & Public Lands Department retained Steiner Thuesen PLLC to plan and design irrigation systems for nineteen Parks and Mountview Cemetery. The project scope included design of fully automated irrigation systems and construction management during the installation process.

The design of the systems and construction management included GPS mapping of each of the sites. The data was imported into our CAD environment to be used as base maps for the irrigation system design. The completed designs were exported back into the GPS environment and used to provide layout and staking of



Water right restrictions prevented one of the sites from pumping water from an irrigation canal at a high enough rate to satisfy the 8 hr. water requirement. After exploring several options, the best long-term solution was to modify an existing storm water reten-



tion area to function as a reservoir. This allows water to be transferred from the canal to the reservoir over a 24 hr. period at a rate that is within the Owner's water rights. The pump station then moves water from the reservoir to the irrigation system at a rate high enough to satisfy the 8 hr / day, 5 day / week requirements. The 1.2 million gallon reservoir holds enough water for approximately 3 days of irrigation.

The Construction Documents were ready for bidding in February of 2003. The available funding, \$2.6 million, allowed for the design of all 19 parks, the cemetery, and installation of irrigation systems for the seven highest priority parks. Systems were installed at Pioneer, South, Rose, Castlerock, Stewart, Optimist, and Lillis Park.



Construction began in April and was completed in October of the same year. In all, this project included the design of 280 acres of irrigation representing approximately \$6.3 million of construction.

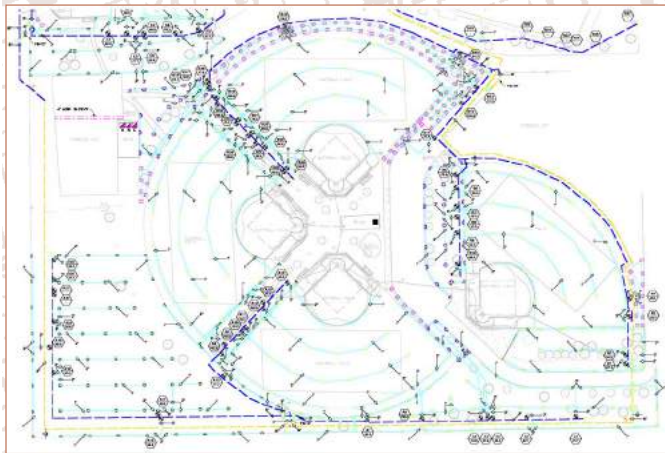

the new irrigation systems. During installation of the systems, the as-built information was collected with a GPS system and used to create record drawings for use by the Owner. The as-built information was also imported into the Owner's GIS database.

Initially, a thorough evaluation of the available irrigation equipment was made. Based on recommendations by our office and the Owner's experience, the equipment to be incorporated in to the design was selected. Design of the irrigation systems followed.

One of the requirements of the design mandated that each of the irrigation systems operate within an 8 hr / day, 5 day / week watering window to allow sufficient time for maintenance activities and minimize user conflicts. This was accomplished through design of highly efficient systems with a scheduling coefficient of 1.2 or better and fully automated pump stations capable of delivering the high flows necessary to meet the 8 hour water window requirement.

WARM SPRINGS STATE HOSPITAL

Warm Springs, Montana

Consolidation of many of the Warm Springs State Hospital functions into a single new building triggered a need to address the campus landscape and irrigation systems in a comprehensive manner. Steiner Thuesen PLLC provided this service to the state of Montana as a consultant to the project architects, Schlenker & McKittrick of Helena. The project budget for landscape and irrigation was \$250,000.

Landscape plans were prepared for the 12.5 acre grounds for the new building. These plans and the building siting were designed to maximize the use of existing mature trees to maintain the present campus character. Special consideration was given to two enclosed courtyards within the building.

Development of the irrigation plans involved a broader look at the whole campus environment. In doing so, the water supply, irrigation mainlines and irrigation controls were sized to serve the entire campus, although only the new building area would be constructed initially.

The old campus water well was being abandoned, since new water service was being piped in from the Anaconda municipal system. New high efficiency motors and vertical turbine pumps were used to replace the old pumping equipment. The new pumps are controlled by a digitally activated variable frequency drive responding to downstream pressure and flow.

An expandable master / satellite control system was used, and was conceptually designed to serve the entire campus. This easy to operate system offers digital timing accuracy at the satellite controllers and basic global operations from the electro-mechanical central controller. The system serves the sizable turf areas with rotor sprinkler heads, while spray heads are used to irrigate planted beds and small areas.

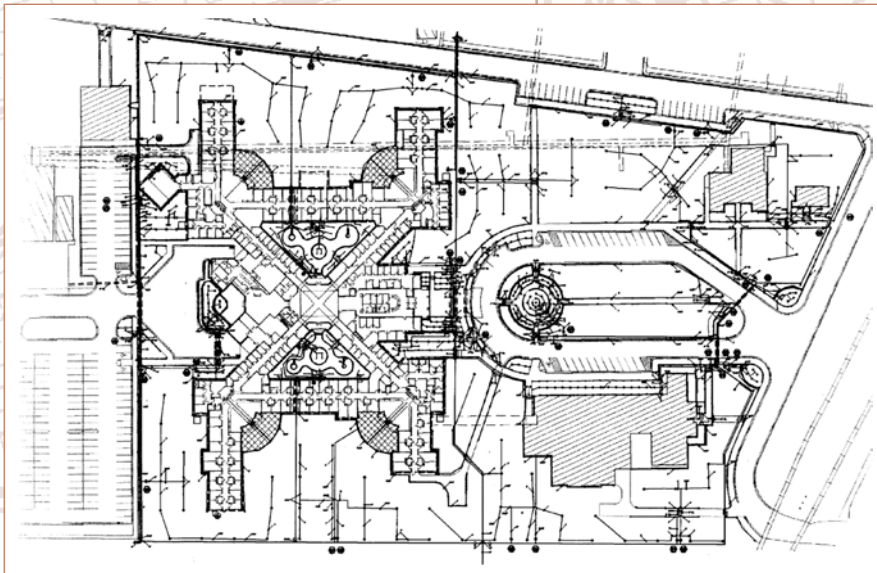

IRRIGATION DESIGN

MONTANA STATE CAPITOL

Helena, Montana

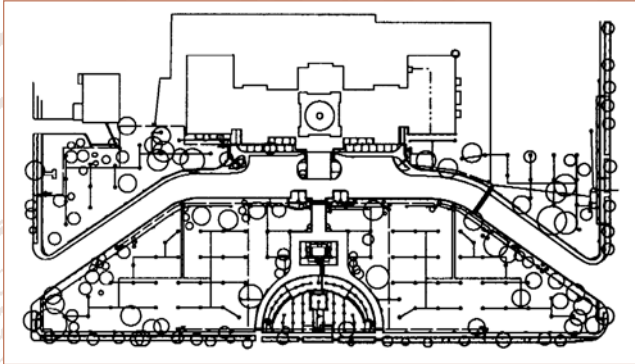

Plans for automatic irrigation of the Montana State Capitol grounds were developed for the Montana Department of Fish, wildlife and Parks. The grounds were formally watered with a manual system, resulting in uneven coverage, overwatering and use of expensive manpower.



The new system provides uniform precipitation coverage for beautiful evenly green lawns and greatly reduced labor input needs. In addition to the lawns, the Montana flower bed is also watered. The bed design changes each year. It presents a popular photo viewpoint for tourists visiting the Capitol complex.



MALMSTROM AIR FORCE BASE

Great Falls, Montana

Steiner Thuesen PLLC was retained as the Landscape Architectural consultant to local engineering firm SMD Engineering, Inc. to assist in fulfillment of their open-end contract with Malmstrom Air Force Base. Three major landscape and irrigation projects were completed during the previous three years.

The first of these projects was the Museum Irrigation System. A new, automated irrigation system was designed and constructed in the 6 acres of landscape and turf at the Museum.

Shortly after the Museum project, design work began on the Central Irrigation Control System. This project, allows all covered irrigation sites to be programmed and monitored from one central location. Installation of the weather station provides constant monitoring of environmental conditions. The central computer uses this information daily to calculate and adjust irrigation run times for each individual irrigation zone based on evapotranspiration as well as other weather conditions. The updated times are downloaded to each of the field controllers ensuring that plantings and turf receive only the amount of water needed to maintain health and vigor.

The implementation of the Toro Sentinel Central Control System (formerly *Eicon Ceres*) augments water conservation while reducing maintenance costs and enhancing the areas included in the project. The existing irrigation systems at approximately 50 sites were modified and brought on line with the central control system.

The final project of the open-end contract is the development of a Landscape Implementation Master Plan for the entire Base. Phase I of the project included investigative services to break the site down into zones and recommend priorities for implementation of the Master Plan. Three 'types' of landscaping and the associated 'levels of effort' were defined.



The Plan addresses aesthetics, conservation, maintenance, plantings, irrigation, and provides recommendations for planting types, soil amendments, turf seed mixes, and irrigation treatments.

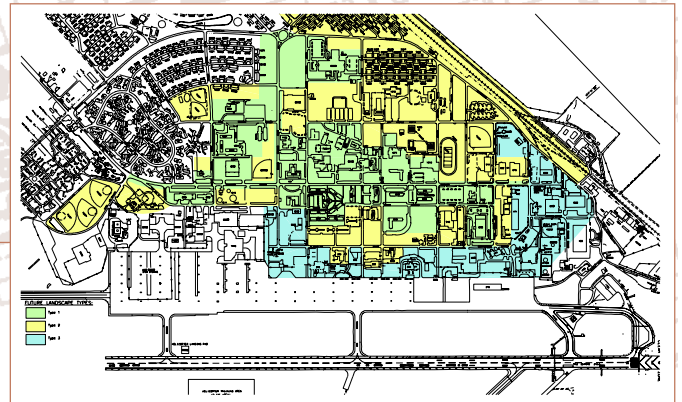

Phase II of this undertaking is the development of construction documents that implement the Master Plan along Goddard Drive, the main vehicular and pedestrian corridor on the base. Demolition, landscape, and irrigation plans for several sites adjacent to this main street were produced for visual enhancement of the corridor.

Site inventories of the affected areas were completed to locate and identify existing plant material, evaluate current means of irrigation, and analyze overall site conditions. Soils tests were performed and evaluated allowing recommendations to be made for soil amendments to promote healthy turf and plant material.

Booster pumps are incorporated in the project to provide the necessary water pressure ensuring successful performance of the irrigation systems. The proposed irrigation systems will be incorporated into the existing Central Irrigation Control System.

These three projects represent approximately \$2,100,000 of construction.



IRRIGATION DESIGN

POLSON COUNTRY CLUB

Polson, Montana

Nine holes were added to Polson Country Club as part of the Mission Bay development. Steiner Thuesen PLLC was retained by the City as irrigation consultant, working with golf architect John Steidel who was retained by the developer.



The firm provided an extensive hydrologic analysis of the golf course irrigation supply and developed plans which permitted the City to expand its existing well. An alternative water source was developed using existing water rights from a canal which crossed the golf course property. The two water sources, and corresponding reservoirs, were interconnected using the irrigation system piping and pumps so that water could be used from either source automatically.

A wall-to-wall irrigation system was designed, making extensive use of part-circle equipment to provide full coverage from property line to property line through the golf corridor. The Owner's existing irrigation control system was updated and incorporated in the new design.



HILANDS GOLF CLUB IRRIGATION SYSTEM REPLACEMENT

Billings, Montana

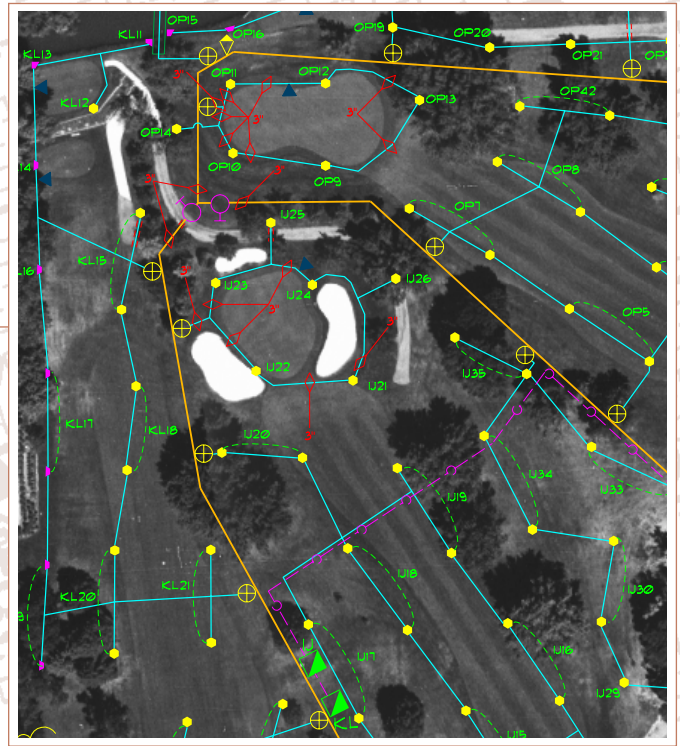

After a thorough evaluation and budgeting process, plans were prepared to replace the aging irrigation system at this classic 9 hole golf club. The existing pumps were renovated with the addition of new self-governing controls and a pressure maintenance pump. Existing pump electrical systems were replaced. The remainder of the irrigation system was completely replaced with new sprinkler equipment, computerized controls, and piping. To minimize disruption of the course by the replacement construction the controls used radio communications. The entire property was irrigated, fence to fence.

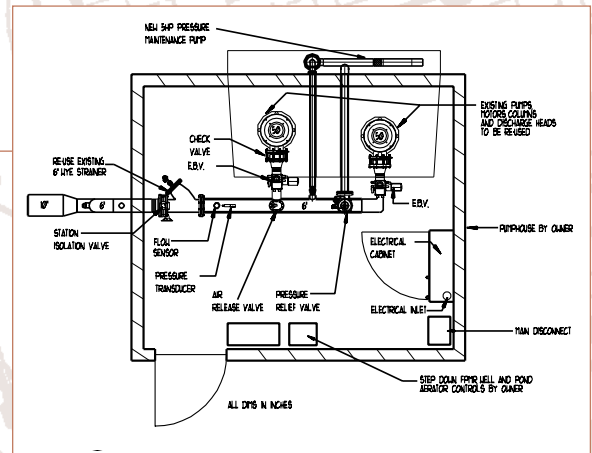

BIG SKY GOLF COURSE IRRIGATION SYSTEM REPLACEMENT

Big Sky, Montana

Construction plans were prepared to replace the irrigation system on this Arnold Palmer designed 18 hole golf course using treated effluent as a water source. The enhanced coverage provided by the wall-to-wall system covers 193 acres, delivering 3,600 gallons per minute. A central computer controls the system automatically while optimizing performance of the three variable frequency drive main pumps and three horizontal centrifugal booster pumps.



As in all of our remodeling work special design and construction methods were used to maintain golf course playability to the maximum extent possible during the construction process.



"I attribute Carl's fresh approach and irrigation design innovations with successful cost control and construction period mitigation for this difficult project."

Ron Edwards, General Manager
Big Sky Water & Sewer District

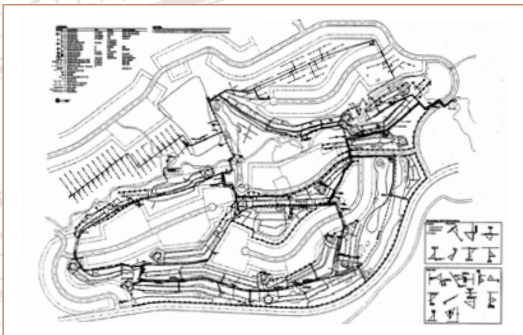

IRRIGATION DESIGN

BELL NOB GOLF COURSE

Gillette, Wyoming

Our consulting relationship with Bell Nob has been on-going for nearly a decade. The course was constructed by a land developer and purchased by Campbell County several years later when the developer met with financial difficulty. Many of the course construction solutions had initially been driven by economics, that is to say what would be least expensive to build, without consideration for maintainability or future quality. The County's golf course superintendent, Dwayne Dillinger, CGCS, set out to correct these deficiencies. Dwayne's goal was to improve playing conditions on the course while reducing maintenance costs and inputs.



Initially, Steiner Thuesen PLLC was retained to prepare a long range master plan for course improvements. The plan focused on adjustments to the course layout to improve play, and on development of better grassing definition to reduce the area under irrigation. Expensive potable water was used to irrigate the golf course, as it is the only suitable source available. Purchase of water was the single largest line item in Dwayne's annual budget. Recommendations were made reducing green turf by 25%, bringing native prairie more into play.

Next construction documents were prepared for replacement of the irrigation system. Although this design was not funded by the County in its entirety, it did result in replacement of the courses' aging control system with centralized computer controls. Several years later the old pumps were modernized. Once again our design served as the guideline for the replacement systems.

Most recently, we were retained to update our earlier irrigation system replacement design, which was installed during July and August 2001. The design was worked out to provide very uniform irrigation coverage using independent testing data for the sprinklers and specialized design software. Many part-circle heads and smaller heads running on block valves were used to achieve the acreage reduction and grassing definition envisioned years earlier in the master plan. Several course improvements including fairway drainage, bunker closures, mounding and tee additions were also included in the contract per the original master plan.



The golf course was not closed during construction. In fact, the Wyoming mid-am and several other tournaments were hosted while construction was in progress. A temporary hole was used to provide 18 holes of play at all times. Special installation methods resulted in virtually no damage to the golf course. Thuesen provided GPS as-built mapping of the project as it was installed. The mapped data was then converted directly to the control software format and input to the computer, permitting on screen control of individual heads from the central controller or from a palm computer.



TETON SPRINGS GOLF & CASTING CLUB

Victor, Idaho



• golf course design team - left to right •
 Bob Ablondi, Carl Thuesen, Steve Jones, Byron Nelson, Mike Etchemendy, Gary Stevenson

Steiner Thuesen PLLC was retained initially to provide golf corridor definition and preliminary master plan level course routing for this resort development located at the western foot of Teton Pass. The office was also responsible for extensive water use calculations to demonstrate that the development would maintain irrigation water consumption within existing water rights.

Following plan approval the firm was retained to design the golf course irrigation system, encompassing nearly 700 acres. The system provides raw water for irrigation of the golf course, landscaped commonly held open space and for the individual lots. It is automatically controlled using computers to monitor flows and to adjust for varying weather conditions. Two custom-designed computer-controlled pump stations furnish the 6,000 gallons per minute needed for system operation.

The irrigation system design was prepared working with golf architect Gary Stevenson, course superintendent Mike Etchemendy, civil engineer Bob Ablondi, consulting touring pro and US Open champion Steve Jones, and golf legend Byron Nelson.



Project Master Plan

IRRIGATION DESIGN

YELLOWSTONE COUNTRY CLUB

Billings, Montana

Steiner Thuesen PLLC was retained to prepare construction documents for replacement of the irrigation system that services the 18-hole course. The wall-to-wall design, including 1,400 sprinkler heads, replaced the old irrigation system including the control system and pump station. Independent irrigation head test data and specialized design software was used to provide uniform irrigation coverage resulting in an overall reduction of water and energy use.

Historically, the golf course irrigation cycle could not be completed in a timely manner due to undersized pumps and mainlines. This caused conflict with golfers and maintenance work. The new design uses a fully automated, 3,800 gallon per minute, pump station to supply water



to the new irrigation system. The station includes (4) 100 horsepower and (1) 30 horsepower vertical turbine pumps with premium efficient motors, all running on variable frequency drives. Automatic filtration and a fertigation pump were included in the station design. The new design features correctly sized mainline piping to convey the water to the course, allowing complete and efficient use of the pumps' full capabilities. If needed, under stress or tournament conditions, the entire grounds can now be irrigated in just a few hours.

Formost Construction Company, the largest golf course irrigation contractor in the world, installed the new system using custom built machinery pictured above. The construction cost was approximately \$1.85 million.



1925 GRAND AVENUE
SUITE 105
P.O. BOX 22943
BILLINGS, MT 59104
406 | 252-5545
FAX | 245-9855

